

## B. E.

### Third Semester Examination, Dec.-2007 Engineering Mechanics (ME-205-E)

**Note :** Attempt only *FIVE* questions. All questions carry equal marks.

**Q. 1. (a)** Solve for the reactions at four points on the two cylinders of radii 300 mm and 150 mm show in fig.

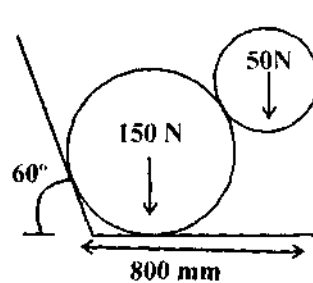

Ans. 
$$\sin \theta = \frac{600 - 150 - 300 \tan 30}{150 + 300}$$

$$\Rightarrow \theta = 38^\circ$$

From free body diagram,

$$R_1 \cos \theta = 50$$

$$R_1 \sin \theta = R_4$$

$$R_1 \sin \theta = R_2 \sin 60$$

$$R_2 \cos 60 + R_3 = R_1 \cos \theta + 150$$

Solving the above equations

$$R_1 = 63.45 \text{ N}, R_2 = 45 \text{ N}, R_3 = 177.5 \text{ N}, R_4 = 39 \text{ N}.$$

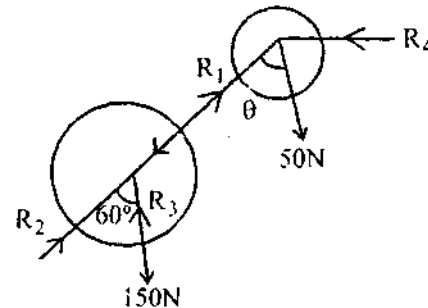

**Q. 1. (b)** Find the moment of 5kN force about A as shown in the fig.

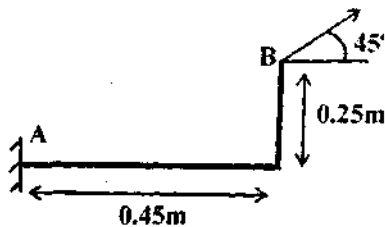

Ans. Moment 
$$= 5 \cos 45^\circ \times 0.25 + 5 \sin 45^\circ \times 0.45$$
  

$$= 2.47 \text{ KNM}.$$

**Q. 2.** A truss of 8m span is loaded as shown in fig. Find the forces in the members of the truss by the method of sections.

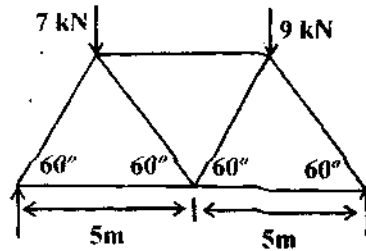

Ans. Taking moments about D,

$$R_A \times 10 = 7 \times 7.5 + 9 \times 2.5$$

$$\Rightarrow R_A = 7.5 \text{ KN}$$

$$\begin{aligned} \therefore R_D &= 9 + 7 - 7.5 \\ &= 8.5 \text{ KN} \end{aligned}$$

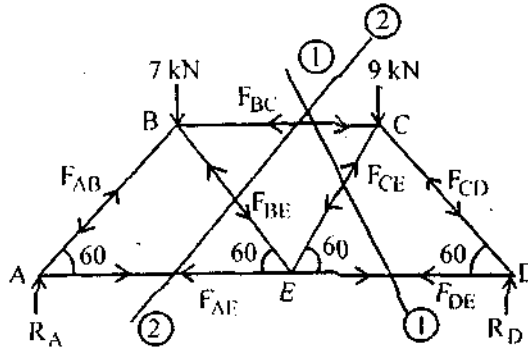

Taking section (1)-(1) as shown,

$$F_{CE} \cos 30 + 8.5 = 9 \Rightarrow F_{CE} = 0.577 \text{ KN (compressive)}$$

But,  $-F_{BC} + F_{DE} = F_{CE} \sin 30$  &  $R_D \times 2.5 = F_{DE} \times 4.33$

$$\Rightarrow F_{DE} = 4.9 \text{ KN (Tensile)}, F_{BC} = 4.6 \text{ KN (compressive)}$$

$$F_{CD} = \frac{(F_{CE} \cos 60 + F_{BC})}{\sin 30} = 9.7 \text{ KN (compressive)}$$

Taking section (2)-(2)

$$F_{BE} \cos 30 + 7.5 = 7 \Rightarrow F_{BE} = -0.577 \text{ KN} = 0.577 \text{ KN (Tensile)}$$

$$F_{BC} = F_{AE} + F_{BE} \cos 60 \Rightarrow F_{AE} = 4.3 \text{ KN (Tensile)}$$

$$F_{AB} = \frac{7 + 0.577 \cos 30}{\cos 30} = 8.66 \text{ KN (Compressive)}$$

**Q. 3. (a) A square hole is punched out of a circular lamina of radius 3m, a diagonal of such a square being along any radius of the circle with one vertex at the centre of the circular lamina. The length of the said diagonal is equal to the radius of circular lamina. Find the centre of gravity of the remainder.**

Ans. Radius of circle = 3m  
 Diagonal of square = 3m  
 Side of square =  $\frac{3}{\sqrt{2}}$  m

Let  $X_c$  be distance of centre of gravity from Y-axis

$$x_c = \frac{A_1 x_1 + A_2 x_2}{A_1 - A_2}$$

$$= \frac{z \times (3)^2 \times (0) + \left( -\frac{(3)^2}{2} \right) \left( -\frac{3}{2} \right)}{z(3)^2 - \frac{(3)^2}{2}} = \frac{27/4}{9z - 9/2}$$

$$= 0.285$$

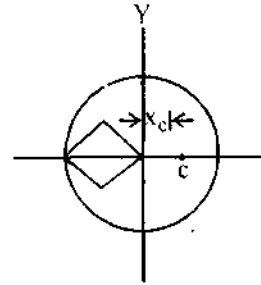

Q. 3. (b) A body consists of a right circular solid cone of height 22 cm and radius 16 cm placed on a solid hemisphere of radius 16 cm of the same material. Find the position of centre of gravity.

Ans. Let  $Y_c$  be distance of CG of body from 'X' axis.

$$Y_c = \frac{V_1 y_1 + V_2 y_2}{V_1 + V_2}$$

Now  $V_1 = \frac{2}{3} \pi r^3$ ,  $y_1 = r - 3r/8 = 5r/8 = \frac{5 \times 16}{8} = 10$  cm

$\Rightarrow V_1 = \frac{2}{3} \times \pi \times (16)^3 = 8578.6 \text{ cm}^3$

$$V_2 = \frac{\pi}{3} r^2 h = \frac{\pi}{3} \times (16)^2 \times 22 = 5897.8 \text{ cm}^3$$

$$y_2 = r + \frac{h}{4} = 16 + \frac{22}{4} = 21.5 \text{ cm}$$

$$\therefore Y_c = \frac{8578.6 \times 10 + 5897.8 \times 21.5}{8578.6 + 5897.8} = 14.68 \text{ cm}$$

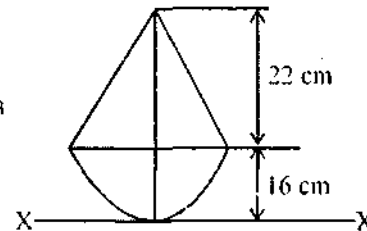

Q. 4. (a) State and prove the theorems of parallel axis and perpendicular axis.

Ans. **Theorem of Parallel Axis (or Transfer-Formula)** : The theorem of parallel axes states : "The moment of inertia of a lamina about any axis in the plane of the lamina equals the sum of moment of inertia about a parallel centroidal axis in the plane of lamina and the product of the area of the lamina and square of the distance between the two axes."

In fig., is shown a lamina of area A. Let LM be the axis in the plane of lamina about which the moment of inertia of the lamina is required to be found out. Let XX be the centroidal axis in the plane of the lamina and parallel to the axis LM. Let 'h' be the distance between the two axes XX and LM.

It may be assumed that the lamina consists of an infinite number of small elemental components parallel to the axis XX. Consider one such elemental component at a distance y from the axis XX. The distance of the elemental component from the axis LM will be the  $(h \pm y)$  accordingly as the elemental component and the axis LM are on the opposite sides of XX or on the same side of XX.

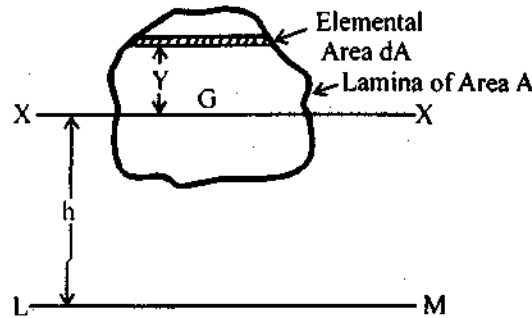

Moment of inertia of the elemental component about the axis

$$LM = dA(h \pm y)^2$$

∴ Moment of inertia of the whole lamina about the axis LM

$$\begin{aligned} &= I_{LM} = \Sigma dA(h \pm y)^2 \\ &= \Sigma dAh^2 + \Sigma dAy^2 \pm 2\Sigma dAhy \\ &= h^2\Sigma dA + \Sigma dAy^2 \pm 2h\Sigma dAy \end{aligned}$$

But,

$$\Sigma dA = A \quad \therefore h^2\Sigma dA = Ah^2$$

$\Sigma dAy^2 =$  Moment of inertia of the lamina about the axis XX

$\Sigma dAy = 0$  since XX is a centroidal axis

$$\therefore I_{LM} = I_{XX} \text{ (or } I_G) + Ah^2$$

**Theorem of Perpendicular Axes :** The theorem of perpendicular axes states : "If  $I_{ax}$  and  $I_{ay}$  be the moments of inertia of a lamina about mutually perpendicular axes OX and OY in the plane of the lamina and  $I_{az}$  be the moment of inertia of the lamina about an axis (OZ) normal to the lamina and passing through the point of intersection of the axes OX and OY.

$$\text{Then} \quad I_{oz} = I_{ox} + I_{oy}$$

Refer fig. Let OX and OY be the two mutually perpendicular axes lying in the plane of the lamina. Let OZ be axis normal to the lamina and passing through O.

Consider an element component of area dA of the lamina. Let the distance of this elemental component from the axis OZ, i.e., from O be r.

∴ Moment of inertia of the elemental component OZ,

$$= dA \times r^2$$

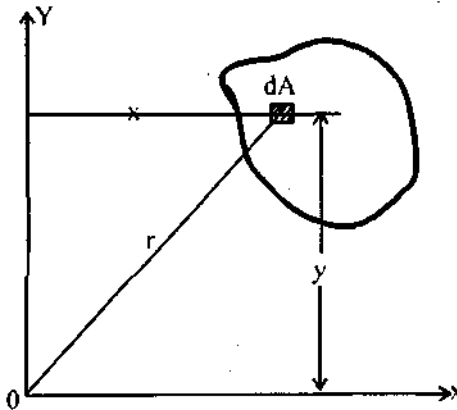

If the co-ordinates of the elemental components be  $(x, y)$  referred to the axes OX and OY, we have

$$r^2 = x^2 + y^2$$

Moment of inertia of the elemental component about the axis OZ.

$$= dA(x^2 + y^2)$$

$$= dAx^2 + dAy^2$$

∴ Total moment of inertia of the lamina about the axis OZ.

$$= I_{OZ} = \Sigma(dAx^2 + dAy^2)$$

$$= \Sigma dAx^2 + \Sigma dAy^2$$

$$= I_{Ox} + I_{Oy}$$

**Q. 4. (b) Derive an expression for moment of inertia of a semi-circular lamina of radius R.**

**Ans.**

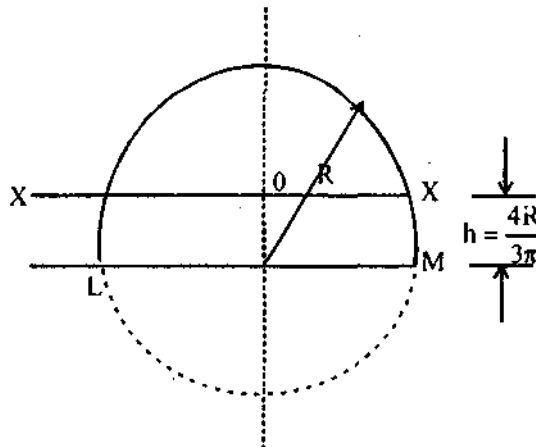

We know that the moment of inertia of a circular lamina about a diameter LM

$$= \frac{\pi R^4}{4} = \frac{\pi D^4}{64}$$

∴ Moment of inertia of the semi-circle about LM

$$I_{LM} = \frac{\pi R^4}{8} = \frac{\pi D^4}{128}$$

Let XX be centroidal axis parallel to the base LM. Let h be the distance between the axis XX and LM. We have

$$\begin{aligned} h &= \frac{4R}{3\pi} \\ &= \frac{4}{3\pi} \times \frac{D}{2} \\ &= \frac{2D}{3\pi} \end{aligned}$$

By theorem of parallel axis, we have

$$\begin{aligned} I_{LM} &= I_{XX} + Ah^2 \\ \frac{\pi R^4}{8} &= I_{XX} + \frac{\pi R^2}{2} \times \left(\frac{4R}{3\pi}\right)^2 \end{aligned}$$

From which 
$$I_{XX} = \frac{\pi R^4}{8} - \frac{8\pi R^4}{9\pi^2}$$

Or 
$$I_{XX} = \frac{\pi R^4}{8} - \frac{8R^4}{9\pi}$$

Or 
$$I_{XX} = 0.111R^4$$

$$I_{yy} = \frac{\pi R^4}{8} = \frac{\pi}{128} D^4$$

**Q. 5. Two guns are pointed at each other one upward at an angle of 30° and the other at the same angle of depression the muzzles being 40m apart. If the guns are shot with velocities of 320m/s upwards and 280 m/s downwards respectively, find when and where the shots will meet.**

Ans. Let shots meet at P after t seconds.

Horizontal distance between A & B,

$$AC = 40 \cos 30 = 34.64 \text{ m}$$

Horizontal distance covered by shot fired from A in t seconds

$$x = AD = 320 \cos 30 \times t = 277.13t \quad \dots(i)$$

Horizontal distance covered by shot fired from B in t seconds

$$DC = (34.64 - x) = 280 \cos 30 \times t = 242.5t \quad \dots(ii)$$

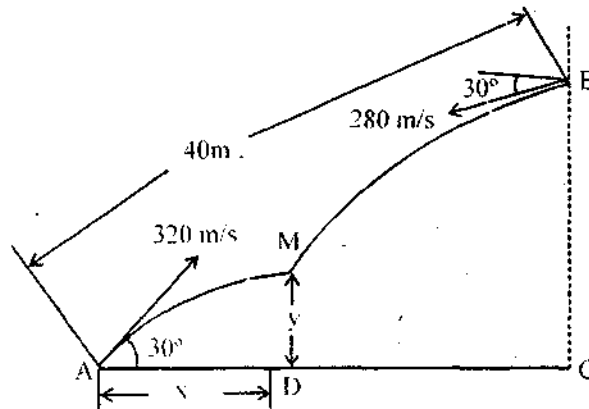

Adding (i) & (ii)

$$34.64 = (277.13 + 242.5)t = 519.6t$$

$\Rightarrow$

$$t = 34.64 / 519.6 = 0.067s$$

Now,

$$x = V \cos \alpha \times t = 320 \cos 30 \times 0.067 = 18.56m$$

$$y = V \sin \alpha \times t - \frac{1}{2}gt^2$$

$$= 320 \sin 30 \times 0.067 - \frac{1}{2} \times 9.81 \times (0.067)^2$$

$$= 10.66m$$

**Q. 6. (a)** A sphere of mass 0.25 kg is attached to an in extensible string of the length 1.5m, whose upper end fixed to the ceiling. The sphere is made to describe a horizontal circular of radius 0.5m. Determine : (a) The time taken for one revolution (b) The tension in the string.

Ans. Let T be the tension,

$$\theta = \cos^{-1} \frac{r}{l} = \cos^{-1} \frac{0.5}{1.5}$$

$$= 70.5^\circ$$

$$T \sin \theta = mg$$

$\Rightarrow$

$$T = \frac{0.25 \times 9.81}{\sin 70.5}$$

$$= 2.6N$$

Time period,

$$t = \frac{2\pi}{\omega}$$

$$T \cos \theta = m\omega^2 r \Rightarrow \omega = \sqrt{\frac{T \cos \theta}{mr}} = \sqrt{\frac{2.6 \cos 70.5}{0.25 \times 0.5}}$$

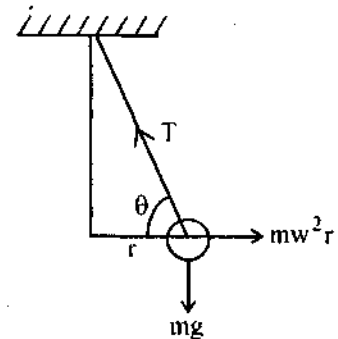

$$\Rightarrow \omega = 2.63 \text{ rad/s}$$

$$\therefore t = 0.24 \text{ seconds.}$$

**Q. 6. (b) State and explain the D'Alembert's principle for the motion of rotation.**

**Ans.** The D'Alembert's principle can be stated as follows: "When internal or external turning moments or torque acts on a system having rotating motion the algebraic sum of all the torque acting on the system including the inertia torques taken in opposite direction of angular acceleration is zero."

Let us consider a disc of moment of inertia  $I$  rotating at an angular acceleration  $\alpha_1$  under the influence of torque  $T$ , acting in clockwise direction. The inertia torque  $= I\alpha$  will act in anticlockwise direction.

As per D'Alembert's principle

$$T - I\alpha = 0$$

This is known as dynamic equation of equilibrium for rotating system on lines of equation.

$$\Sigma M = 0 \text{ for static equilibrium.}$$

**Q. 7. Explain the principle of Virtual Work. Solve the beam for reactions at supports shown in fig. (4), by virtual work method.**

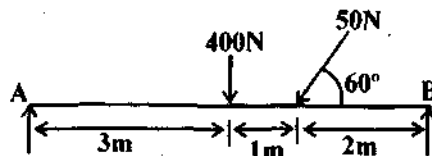

**Ans.** The principle of virtual work may be stated as: The work done on a rigid body or a system of rigid bodies in equilibrium, when acted upon a set of forces, is zero for any virtual displacement compatible with the constraints on the system.

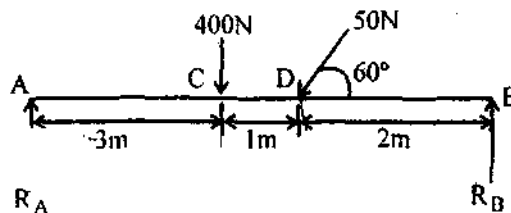

At B let a vertical virtual displacement  $\delta_b$  is given holding end A in position.

$$\therefore \frac{\delta_c}{3} = \frac{\delta_d}{4} = \frac{\delta_b}{5}$$

$$\Rightarrow \delta_c = \frac{3}{5} \delta_b \qquad \delta_d = \frac{4}{5} \delta_b$$

$$\begin{aligned} \text{Total work} &= R_B \times \delta_b - 50 \sin 60 \delta_d - 400 \delta_c + R_A \times 0 \\ &= R_B \times \delta_b - 50 \sin 60 \times \frac{4}{5} \delta_b - 400 \times \frac{3}{5} \delta_b \end{aligned}$$

According to principle of virtual work

$$0 = R_B \times \delta_b - 274.64 \delta_b$$



⇒

$$R_B = 274.64 \text{ N}$$

$$R_A = 400 + 50 \sin 60 - 274.64 = 168.66 \text{ N}$$

**Q. 8. Discuss the following with suitable examples :**

(a) Principal moments of Inertia

(b) Static indeterminacy

(c) Coriolis forces.

**Ans. (a) Principal Moment of Inertia :** If the two axes about which the product of inertia is found are such that the product of inertia becomes zero, the two axes are called principal axes. The moment of inertia about principal axes is called principal moment of Inertia.

**(b) Static Indeterminacy :** A structure is statically indeterminate when the static equilibrium equations are not sufficient for determining the internal forces and reactions on that structure.

For a beam ABC as shown the equilibrium equations are

$$\Sigma V = 0$$

$$V_A - F_V + V_B + V_C = 0$$

$$\Sigma H = 0$$

$$H_A - F_h = 0$$

$$\Sigma M = 0$$

$$F_V \cdot a - V_B(a + b) - V_C(a + b + c) = 0$$

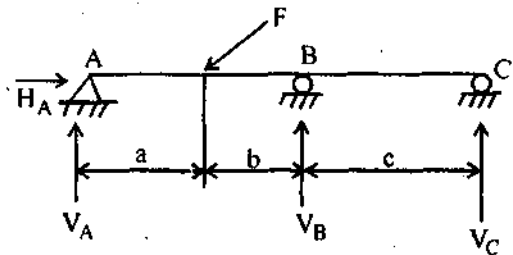

Since there are four unknown  $[V_A, V_B, V_C \text{ and } H_A]$  but only three equations are available. Hence this system can't be solved by simultaneous equation. The structure is therefore classified statically indeterminate.

**(c) Coriolis Forces :** The Coriolis effect is an apparent deflection of moving objects when they are viewed from a rotating frame of reference. The Coriolis effect is caused by Coriolis force which appears in equation of motion of an object in rotating frame at reference. In rotating frame, the Coriolis force depends on the velocity of moving object and centrifugal force.

The vector formula for the magnitude and direction of Coriolis acceleration is

$$\vec{a}_c = -2\vec{\omega} \times \vec{v}$$

The equation may be multiplied by the mass of relevant object to produce the Coriolis force.

$$\vec{F}_c = -2m\vec{\omega} \times \vec{v}$$